

**TESTING AND MONITORING PLAN
47 CSR 13-13.6.2**

Project Name: Tri-State CCS Redbud 2

Facility Information

Facility contact: Tri-State CCS, LLC
14302 FNB Parkway
Omaha, NE 68154
402-691-9500

Well location: Marshall County, West Virginia

Well Name	Latitude (WGS 84)	Longitude (WGS 84)
TR2-1	40.016375	-80.606419
TR2-2	40.011884	-80.533589
TR2-3	39.978333	-80.600234
TR2-4	39.956423	-80.635316

Table of Contents

List of Figures	3
List of Tables	3
List of Appendices	3
List of Acronyms	4
1. Introduction.....	6
2. Overall Strategy and Approach for Testing and Monitoring.....	6
2.1. Plan Strategy and Approach.....	6
2.2. Baseline Testing and Monitoring.....	10
2.3. Conceptual Monitoring Network Design.....	13
2.4. Quality Assurance Procedures	20
2.5. Reporting Procedures	20
3. Carbon Dioxide Stream Analysis.....	21
3.1. Sampling Location and Frequency.....	22
3.2. Analytical Parameters	22
3.3. Sampling Methods.....	22
4. Continuous Recording of Operational Parameters	23
4.1. Monitoring Location and Frequency.....	24
4.2. Injection Rate, Volume, and Pressure Monitoring.....	24
4.3. Annulus Pressure & Fluid Volume Monitoring.....	25
4.4. Injection Temperature Monitoring.....	26
5. Corrosion Monitoring	27
5.1. Monitoring Location and Frequency.....	27
5.2. Sample Description	27
5.3. Monitoring Details	28
6. Above Confining Zone Monitoring	29
6.1. Monitoring Location and Frequency.....	30
6.2. Analytical Parameters	31
6.3. Sampling Methods.....	32
6.4. Laboratory to be Used/Chain of Custody Procedures.....	32
7. Mechanical Integrity Testing.....	33
7.1. Testing Location and Frequency	34
7.2. Testing Details.....	34
8. Pressure Fall-Off Testing.....	35

8.1. Testing Location and Frequency	35
8.2. Testing Details.....	36
9. Carbon Dioxide Plume and Pressure Front Tracking	36
9.1. Plume Monitoring Location and Frequency.....	39
9.2. Plume Monitoring Details	39
9.3. Pressure-Front Monitoring Location and Frequency	40
9.4. Pressure-Front Monitoring Details.....	40
10. References.....	41

List of Figures

Figure 1: Generalized stratigraphic column identifying primary (1 & 2) and secondary (3) storage complexes with corresponding storage reservoirs and confining zones	8
Figure 2: Simplified layout of storage complex depicting location of testing and monitoring equipment.....	14
Figure 3: Locations of proposed injection and in-zone observation wells (TR2-IOB), oil and gas wells, water wells, the AoR, and the plume and pressure front boundaries.	18
Figure 4: Annular monitoring system.	26
Figure 5: (Left) Example of corrosion coupon holders. (Right) Flow through pipe arrangement example.	29
Figure 6: Project CO ₂ plume evolution map after 30 years of injection and 50 years post-injection.....	38

List of Tables

Table 1: Project well summary for Tri-State CCS Redbud 2 ¹ . Zone depth are estimates, actual depths will be determined after well data collection.	9
Table 2: Pre-injection testing and monitoring technologies, frequencies, and locations.....	13
Table 3: Testing and monitoring frequencies for all project phases.	16
Table 4: Injection phase testing and monitoring frequencies and locations	19
Table 5: Summary of analytical parameters for CO ₂ stream ¹	23
Table 6: Continuous recording sampling methods, locations, and frequencies.....	24
Table 7: List of equipment coupons with material of construction	27
Table 8: Monitoring geochemical and physical changes.....	30
Table 9: Summary of analytical and field parameters for ground water samples.	32
Table 10: Mechanical integrity testing (MIT) location and frequency.....	34
Table 11: Injection phase pressure fall-off testing frequency and schedule.....	35
Table 12: Indirect CO ₂ plume injection phase monitoring activities.....	40
Table 13: Direct pressure-front injection phase monitoring activities.....	41

List of Appendices

Appendix A: Quality Assurance and Surveillance Plan (QASP)

List of Acronyms

°F	Fahrenheit
Al	Aluminum
ANSI	American National Standards Institute
AOB-#	Above-Zone Observation wells
AoR	Area of Review
AP	Artificial Penetrations
APHA	American Public Health Association
As	Arsenic
ASME	American Society of Mechanical Engineers
ASTM	American Society for Testing and Materials
Ba	Barium
Br	Bromine
Ca	Calcium
CBL	Cement Bond Log
CCS	Carbon Capture and Storage
Cd	Cadmium
CI	Casing Inspection
Cl	Chlorine
CO ₂	Carbon Dioxide
Cr	Chromium
CSR	West Virginia Code of Regulations
Cu	Copper
DH	Downhole
DIC	Dissolved Inorganic Carbon
DTS	Distributed Temperature Sensing
EPA	Environmental Protection Agency
ERRP	Emergency and Remedial Response
Fe	Iron
ft	feet
GC-P	Gas Chromatography-Pyrolysis
gm	Gram
GS	Geologic Sequestration
GW-#	Shallow Groundwater Wells
H ₂ S	Hydrogen Sulfide
ICP	Inductively Coupled Plasma
IOB-#	In-Zone Observation wells
K	Potassium
lb	pound
Mg	Magnesium

MIT	Mechanical Integrity Testing
MMscf	Million Standard Cubic Feet
Mt/y	Thousand Metric Tonnes per Year
Mn	Manganese
mol%	Percentage of Total Moles in a Mixture made up by One Constituent
MS	Mass Spectrometry
Na	Sodium
NACE	National Association of Corrosion Engineers
NO ₃	Nitrate
OES	Optical Emission Spectrometry
P	Pressure
Pb	Lead
pH	potential of Hydrogen
PISC	Post-Injection Site Care
PNC	Pulsed Neutron Capture
ppmv	Parts per Million, Volume
psi	Pounds per Square Inch
psig	Pounds per Square Inch, Gauge
QASP	Quality Assurance and Surveillance Plan
SAPT	Standard Annular Pressure Test
Sb	Antimony
Se	Selenium
Si	Silicon
SO ₄	Sulfate
T	Temperature
TBD	To be Determined
TD	Total Depth
TDS	Total Dissolved Solids
Ti	Titanium
TR2-#	Tri-State CCS Redbud 2 Injection Well Number
TVD	True Vertical Depth
UIC	Underground Injection Control
UOB-#	Lowermost USDW Observation Wells
USDW	Underground Source of Drinking Water
WVDEP	West Virginia Department of Environmental Protection

1. Introduction

This Testing and Monitoring Plan (the “plan”) describes how Tri-State CCS, LLC will monitor Tri-State CCS Redbud 2 (the “project”) pursuant to 47 CSR 13-13.6.2. Data collected during the implementation of this Plan will be used to demonstrate that the wells are operating as planned, the carbon dioxide (CO₂) plume and pressure front are moving as predicted, and to confirm there is no endangerment to Underground Sources of Drinking Water (USDWs). The monitoring data will also be used to validate and adjust the geological models used to predict the distribution of CO₂ within the storage reservoir to support Area of Review (AoR) reevaluations and a non-endangerment demonstration. Results of the testing and monitoring activities described below may trigger action according to the Emergency and Remedial Response Plan (ERRP). In addition, Tri-State CCS, LLC will follow reporting requirements pursuant to 47 CSR 13-13.6.3 as described in subsection 2.5.

2. Overall Strategy and Approach for Testing and Monitoring

Tri-State CCS, LLC’s testing and monitoring will cover three main aspects of the geologic sequestration (GS) project during the project injection phase:

1. Well Integrity
2. Operational Parameters
3. Geologic System Changes

2.1. Plan Strategy and Approach

The purpose of the Testing and Monitoring Plan is to ensure that sufficient geospatial and monitoring data will be collected and used to validate rigorous numerical modeling and support demonstration of USDW non-endangerment over the life of the project. The Plan will be reviewed by Tri-State CCS, LLC at least every five years. After review, Tri-State CCS, LLC will either submit an amended Testing and Monitoring Plan or demonstrate to the UIC Program Director that no amendment to the plan is needed.

Demonstrating the mechanical integrity of the wells in the system is a key aspect of protecting USDWs from endangerment due to injection activities (47 CSR 13-13.6.2.e and f). Operational testing and monitoring include analysis of the CO₂ stream; continuous monitoring of injection rate, volume, and pressure; corrosion monitoring; and pressure fall-off testing. Monitoring and testing of the geologic system changes include ground water quality and geochemical monitoring above the confining zone; direct pressure front monitoring; and direct/indirect CO₂ plume monitoring.

Tri-State CCS, LLC recognizes the nexus of data collection and modeling is the primary pathway to exit the UIC permit, define the post-injection site care (PISC) protocols, and close the CO₂ storage site. As such, Tri-State CCS, LLC is establishing a monitoring program capable of tracking the injected CO₂ plume and pressure front and developing time-lapse datasets for numerical modeling. The near surface/subsurface monitoring protocols to be used in the project’s Testing and Monitoring Plan will provide valuable information to evaluate the performance of the CO₂ injection and storage operations and are to include:

- Above-zone and lowermost USDW fluid sample analyses;
- Above-zone and in-zone direct pressure and temperature measurements;
- Surface to total depth (TD) temperature sensing; and
- Through-casing CO₂ saturation profiling.

Tri-State CCS, LLC plans to drill up to eighteen (18) wells (Table 1), strategically placed in specific formations (Figure 1), to ensure USDW non-endangerment. These wells include four (4) multi-zone injection wells completed in the Lockport Dolomite and Medina Groups, four (4) offset in-zone observation wells completed in the Lockport Dolomite and Medina Groups, two (2) above-zone observation wells completed in the Oriskany Formation, four (4) deep observation wells completed in the lowermost USDW of the Mauch Chunk Group, and up to four (4) shallow USDW wells completed in the Pennsylvanian Strata. We note that a lower stratigraphic interval, the Cambro-Ordovician Knox Group (specifically Rose Run Sandstone), is being considered as a secondary possible injection zone along with the Lockport Dolomite and Medina Groups. If this interval is selected as an injection zone, this plan document will be appropriately updated in consultation with the UIC Program Director.

The remainder of this page intentionally left blank.

System	Series	Stratigraphic Unit (Group or Major Formation)	Aquifer, Confining Zone, or Reservoir	Oil Gas Prod.	Average Depth (ft)	Average Thickness (ft)	Depth/Interval Thickness (ft)									
							TR2-1		TR2-2		TR2-3		TR2-4			
							Depth (ft TVD)	Thickness (ft)	Depth (ft TVD)	Thickness (ft)	Depth (ft TVD)	Thickness (ft)	Depth (ft TVD)	Thickness (ft)		
Pennsylvanian		Pennsylvanian (undivided)	Freshwater Aquifers													
		Mauch Chunk Formation	Base Lowest USDW		268		~167		~273		~340		~291			
Mississippian	U	Greenbriar Ls Fm	Seal (Limestone)													
	Lower	Pocono Grp	Big Injun SS	Conventional Oil Reservoir	●●			↑		↑		↑				
			Sunberry Sh	Seal (Shale)												
			Berea SS	Conventional Oil Reservoir	●●											
Devonian	Upper	Ohio Shale Grp	Seal (Shale)		6,154		~6,058 Thick	~6350 Thick	~6,128 Thick	~6,079 Thick						
		Olentangy Shale Fm														
	Middle	Hamilton Grp		Mahantango Shale Fm					↓		↓		↓			
				Marcellus Shale Fm		Unconventional Oil Reservoir	●●									
	Lower		Onondaga Ls Fm	Seal (Limestone)			6,379	326	6,225	315	6,623	353	6,468	328	6,370	301
			Oriskany SS Fm	Conventional Oil/Gas Reservoir		●●	6,703	43	6,540	42	6,976	45	6,802	44	6,671	43
		Helderberg Grp	Seal (Limestone)		6,791	216	6,582	210	7,021	176	6,846	225	6,715	253		
		Bass Islands Dolomite Grp	Seal (Dolomite)		7,007	141	6,792	140	7,197	125	7,071	148	6,968	152		
Silurian	Upper	Salina Grp	Salina "D" – "G"	Upper Confining Zone (Evaporite/Salt)	●●	7,148	1,528	6,932	1,607	7,323	1,457	7,218	1,561	7,120	1,488	
			Salina "A" – "C"													
			Lockport Dolomite Grp ①													Injection Zone
	Lower	Clinton Grp	Rochester Shale Fm	Middle Confining Zone	●●	9,058	432	8,919	431	9,151	453	9,165	432	8,998	412	
			Dayton/Keefe Fm													
		Medina (Tuscarora SS) Grp ② Informal – "Clinton" & "Medina" sands	Injection Zone	●●	9,490	194	9,350	199	9,604	201	9,596	193	9,410	184		
Ordovician	Upper	Queenston Shale (Juniata) Fm	Lower Confining Zone	●●	9,685		9,549		9,806		9,790		9,594			
		Utica Shale Fm	Unconventional Oil Reservoir	●●		3,251		3,203		3,344		3,243		3,213		
		Trenton Grp	Seal (Limestone)													
	M	Black River Ls Grp														
	Lower	Knox Grp	Wells Creek Fm	Upper Confining Zone	●●	12,894	114	12,753	117	13,148	114	13,052	114	12,807	110	
			Beekmantown Dolomite		●●	13,000	210									
Upper	Knox Grp	Rose Run SS ③	Possible Injection Zone	●●	13,220	105										
		Copper Ridge Dolomite Fm	Lower Confining Zone	●●	13,325	400										
Cambrian		Conasauga Grp	Lowest Seal/Confining Unit													

Figure 1: Generalized stratigraphic column identifying primary (1 & 2) and secondary (3) storage complexes with corresponding storage reservoirs and confining zones at injection wells TR2-1, TR2-2, TR2-3, and TR2-4. Lowermost USDW is also identified for reference. (*Depth is to the top of the Stratigraphic Unit (SU)).

Table 1: Project well summary for Tri-State CCS Redbud 2¹. Zone depth are estimates, actual depths will be determined after well data collection.

Well Types	Well Acronym	Zone Depth (ft MD)	CCS System Zone	Zone Formation	Latitude ⁵ (WGS 84)	Longitude ⁵ (WGS 84)	Quantity	Construction Material
Shallow Groundwater (GW)	TR2-GW-1 TR2-GW-2 TR2-GW-3 TR2-GW-4	TBD	Shallow USDW	Pennsylvanian	40.02911358° 40.02847380° 39.97232484° 39.96439262°	-80.60265525° -80.52935228° -80.59224326° -80.65075222°	Up to 4	Surface to Casing TD: Steel meeting ASTM Standard A53/A53M-06 (ASTM, 2022) or Schedule 40 or 80 PVC.
Lowermost USDW Observation (UOB)	TR2-UOB-1 TR2-UOB-2 TR2-UOB-3 TR2-UOB-4	~ 254 ~ 267 ~ 333 ~ 291	Lowermost USDW	Mauch Chunk Group	40.02920146° 40.02855618° 39.97240722° 39.96447776°	-80.60265474° -80.52935172° -80.59224277° -80.65075179°	4	
Above-Zone Observation (AOB)	TR2-AOB-1 TR2-AOB-2	~ 6,623 ~ 6,656	1 st Permeable Zone	Oriskany Formation	40.01637440° 39.95642244°	-80.60624120° -80.63513679°	2	Surface Casing – • Surface to 50 ft below USDW: J55 ² Long-String – • Surface to Casing TD: L80 ³
In-Zone Observation (IOB)	TR2-IOB-1 TR2-IOB-2 TR2-IOB-3 TR2-IOB-4	~ 8,513 ~ 8,658 ~ 8,571 ~ 8,580 ~ 9,320 ~ 9,479 ~ 9,390 ~ 9,376	Reservoir	Lockport Dolomite Group	40.02915700° 40.02851500° 39.97236800° 39.96443600°	-80.60265500° -80.52935200° -80.59224300° -80.65075200°	4	Surface Casing – • Surface to ~50 ft below based of deepest mined coal seam: J55 ² Intermediate Casing – • Surface to ~150 ft below base of shallow oil & gas production unit: J55 ² Long-String Casing – • Surface to ~150 ft above top of LIC: L80 ³ • ~150 ft above top of LIC to casing TD: 22Cr-80 ⁴
Injection	TR2-1 TR2-2 TR2-3 TR2-4	~ 8,540 ~ 8,779 ~ 8,780 ~ 8,608		Reservoir	Lockport Dolomite Group	40.01637500° 40.01188400° 39.97833300° 39.95642300°		-80.60641900° -80.53358900° -80.60023400° -80.63531600°
		~ 9,350 ~ 9,604 ~ 9,596 ~ 9,410	Medina Group					

¹ TR2=Tri-State CCS Redbud 2

²J55 or other steel meeting API Specification 5CT (API, 2019) depending on availability.

³L80 or other steel meeting API Specification 5CT (API, 2019) depending on availability.

⁴22Cr-80 or higher grade/yield strength corrosion resistant alloy meeting API Specification 5CRA (API, 2023) depending on availability, most current applicable materials testing results from API, AMPP, or other standard bodies focused on CCS or alternative project specific testing and modeling.

⁵Surface hole locations for observation wells will be optimized after data collection from the CarbonSAFE stratigraphic wells. Observation well locations will be finalized prior to the submission of the permit to construct.

The remainder of this page intentionally left blank.

Tri-State CCS, LLC will ensure a certified monitoring well drilling professional is on site in direct charge of actively drilling, constructing, and testing all monitoring wells (47 CSR 59-4). Tri-State CCS, LLC will report to the West Virginia Department of Environmental Protection (WVDEP) within 60 days of the completion of the monitoring wells (47 CSR 60-6). Tri-State CCS, LLC will follow monitoring well drilling and construction guidelines as codified under 47 CSR 60-7 through 60-18. When the monitoring wells are abandoned (either prematurely or at the end of the project), specified abandonment procedures and reporting will be followed in accordance with 47 CSR 60-19. If driven-point wells are utilized, the specific requirements under 47 CSR 60-20 will be followed for installation.

2.2. Baseline Testing and Monitoring

Baseline testing and monitoring for this project includes CO₂ stream characterization, internal and external mechanical integrity, formation water quality, direct pressure and temperature, indirect CO₂ plume monitoring, and hydrogeologic testing (Table 2).

CO₂ stream analysis is a critical element of baseline characterization that will provide the chemical profiles, of which the injectate is monitored for, in the observation wells. Tri-State CCS, LLC will analyze the contents of the CO₂ stream prior to injection, at a sufficient frequency, to yield representative chemical and physical profile data in accordance with 47 CSR 13-13.6.2.a.

Mechanical integrity, internal and external, is a key component of the baseline testing and monitoring program (47 CSR 13-13.5) to ensure there are no significant leaks in the injection tubing, packer, or casing (internal) and through channels adjacent to the injection well bore (external) per 47 CSR 13-13.6.2.e, respectively. A demonstration of internal mechanical integrity will be conducted using an annulus pressure test prior to injection (Section 7). External mechanical integrity will be demonstrated in all injection and in-zone observation wells once prior to injection, using a distributed temperature sensing (DTS) fiber optic cable mechanical integrity test (MIT). For this plan, DTS will be used in lieu of a temperature log to run MITs (Section 7) unless there is a failure of installed fiberoptic monitoring, such as cable shear or surface equipment failure, in which case, temperature log will be used to run MITs.

Formation water quality and geochemical changes will be monitored in all project wells (Table 2) per 47 CSR 13-13.6.2.d. Formation water sampling procedures will be formulated using permanent downhole (DH) and wellhead pressure gauges. These gauges will continuously record and transmit pressure data about the formation water in the reservoir units mentioned above and allow for an estimate of the water to be purged prior to sample collection. Formation water chemistry will be baselined through fluid sampling and analysis in the injection interval of the Lockport Dolomite and Medina Groups in the injection wells (TR2-1, TR2-2, TR2-3, TR2-4), the first permeable unit above the confining zone in the Oriskany Formation (TR2-AOB-1, TR2-AOB-2), the lowermost USDW, in the Mauch Chunk Group (TR2-UOB-1, TR2-UOB-2, TR2-UOB-3, TR2-UOB-4), and the shallow Pennsylvanian aquifers (TR2-GW-1, TR2-GW-2, TR2-GW-3, TR2-GW-4). Analytes will be tested to create a baseline (see Table 9), representative of the pre-operational formation water geochemistry, that can be compared to operational (injection phase) geochemistry monitoring data (Section 5). Formation water sampling and analysis will occur quarterly, one year prior to injection, to capture seasonal variations in the formation water geochemistry. Carbon isotope analyses will be run for all baseline analyses to enable Tri-State CCS, LLC to differentiate

project and natural/background CO₂. During injection operations, isotopic analyses will only occur if loss of containment is detected to help verify project containment.

Formation water quality and geochemistry baseline data will help verify containment during injection operations by detecting changes in injection phase data from the baseline data. Changes in the formation water quality and geochemistry mentioned below can be an indication of loss of containment:

- Increase in total dissolved solids (TDS) can indicate native brines have infiltrated the overlying reservoirs.
- Increasing CO₂ concentration and/or decreasing pH can indicate infiltration of CO₂ into monitoring zones.
- Increased reservoir pressure and/or temperature changes may indicate reservoir zone and monitoring zone connectivity.
- Increase in leached constituents (lead, arsenic, etc.) could be due to the presence of CO₂.
- Significant cation and anion signature change could be due to the presence of CO₂.
- Increase of injectate impurities may indicate CO₂ migration into overlying monitoring zones.

Baseline pressure monitoring will occur in the injection, in-zone, above-zone, and lowermost USDW wells per 47 CSR 13-13.6.2.g.1 and will occur continuously using both DH and wellhead pressure gauges. Direct baseline pressure monitoring in injection and in-zone wells will help reveal natural variations in subsurface pressure. This reservoir zone pressure data will help calibrate model predictions of pressure front propagation and allow for adequate baseline data to help decrease the frequency of false positive and negative loss of containment detection events when compared to injection phase monitoring data. Direct pressure monitoring in the above-zone and lowermost USDW observation wells will allow for a comparison to injection phase monitoring pressure data for early detection of containment loss due to increased pressures from potential out-of-zone reservoir brine and/or CO₂.

Indirect CO₂ plume baseline monitoring will occur at the project per 47 CSR 13-13.6.2.g.2. Tri-State CCS, LLC plans to implement indirect CO₂ plume monitoring using DTS, and pulsed neutron capture (PNC) logging. Baseline data will be acquired prior to injection for comparison to injection phase monitoring data.

PNC logging tools can detect elevated oxygen around the wellbore in the rock formation and therefore the presence of CO₂. PNC logging will be conducted once prior to injection in all injection, in-zone, above-zone, and lowermost USDW observation wells. This baseline logging data will allow for comparison to injection phase monitoring data to determine the vertical location of CO₂ within the injection and in-zone wells, and for early detection of containment loss for above-zone and lowermost USDW observation wells. During injection, PNC logging will only be run in the injection wells, in the event of CO₂ breakthrough, and in any well with monitoring data indicating loss of containment. For the zones above the confining zone, PNC logging will be mainly used as a verification technique to help prove the absence of CO₂. Formation water sampling and analysis will also be used to verify elevated levels of CO₂ and determine if the elevated CO₂ is project related.

DTS data will be used to indirectly monitor the location of the CO₂ saturation plume. Differences in the reservoir temperature and injectate stream temperature will be detected allowing for interpretation of the vertical location of the CO₂ plume near the injection wellbore. As mentioned above, injection and in-zone observation wells will contain DTS on the long string casing and record continuous temperature measurements after well construction and prior to injection. Injection phase monitoring data will be compared to baseline data to determine vertical extent of CO₂ in the injection wells (and eventually the in-zone observation wells), and CO₂ breakthrough in the in-zone observation wells. Reservoir intervals taking CO₂, detected via DTS, will then be used to calibrate reservoir models for better prediction of CO₂ saturation plume behavior through time.

Hydrogeologic testing, which includes pressure fall-off testing, will be conducted once prior to injection at each injection well. This data will be used to better understand any injectivity heterogeneity within the reservoir and to better predict plume movement in reservoir models. During the injection phase, hydrogeologic test data can be compared to DTS and PNC logging data for confirmation of the injection zone interval taking fluid and any potential changes in the reservoir injectivity as a result of injection operations.

Some of the injection and/ or in-zone observation wells will include DAS fiberoptic monitoring technology in addition to DTS. This will allow potential time lapse 3D DAS Vertical Seismic Profile (VSP) or Crosswell Seismic Profile (CSP) surveys for indirect plume front monitoring. A decision on specific wells to be used for seismic profiling will depend on modeling studies, additional site-specific data, and independent observations from the monitoring program as implemented at the site. Additionally, the same infrastructure could be used for passive seismic monitoring.

All necessary data will be collected during the pre-injection phase (Table 2) to represent the in-situ properties prior to injection. Data collected during the injection phase (Table 4) will then be compared to pre-injection phase baseline measurements to ensure containment and protection of groundwater resources.

The remainder of this page intentionally left blank.

Table 2: Pre-injection testing and monitoring technologies, frequencies, and locations.

Monitoring Parameter	Technology/Test	Baseline Phase Frequency (1 year)	Location
Internal MIT	Annulus Pressure Test	1 Prior to Injection	TR2-1, TR2-2, TR2-3, TR2-4
External MIT	1) DTS 2) Ultra Sonic CBL 3) Electromag. CI Logs	1 Prior to Injection	TR2-1, TR2-2, TR2-3, TR2-4; TR2-IOB-1, TR2-IOB-2, TR2-IOB-3, TR2-IOB-4
Formation Water Quality	1) Fluid Sampling & Analysis 2) DH P Gauges	1) Quarterly 2) Continuous	TR2-1, TR2-2, TR2-3, TR2-4; TR2-IOB-1, TR2-IOB-2, TR2-IOB-3, TR2-IOB-4; ¹ TR2-AOB-1; TR2-AOB-2; TR2-UOB-1, TR2-UOB-2, TR2-UOB-3, TR2-UOB-4
Direct Pressure Monitoring	1) P Gauges – Tubing 2) DH P Gauges	Continuous	TR2-1, TR2-2, TR2-3, TR2-4; TR2-IOB-1, TR2-IOB-2, TR2-IOB-3, TR2-IOB-4; TR2-AOB-1; TR2-AOB-2, TR2-UOB-1, TR2-UOB-2, TR2-UOB-3, TR2-UOB-4
Indirect CO ₂ Plume Monitoring Techniques	DTS	1 Year Prior to Injection	TR2-1, TR2-2, TR2-3, TR2-4; TR2-IOB-1, TR2-IOB-2, TR2-IOB-3, TR2-IOB-4
	PNC Logging	1 Prior to Injection	TR2-1, TR2-2, TR2-3, TR2-4; TR2-IOB-1, TR2-IOB-2, TR2-IOB-3, TR2-IOB-4; TR2-AOB-1; TR2-AOB-2; TR2-UOB-1, TR2-UOB-2, TR2-UOB-3, TR2-UOB-4
Hydrogeologic Testing	Pressure Fall-Off Testing		TR2-1, TR2-2, TR2-3, TR2-4

¹ Tri-State CCS, LLC only plans to include DH Pressure Gauges at the four in-zone observation wells and does not plan to conduct fluid monitoring at the four in-zone observation wells.

2.3. Conceptual Monitoring Network Design

This plan describes injection phase components of the geologic testing and monitoring program which includes hydraulic, geochemical, and physical components for characterizing the complex transport processes associated with CO₂ injection. Table 3 lists the planned testing and monitoring frequencies for the pre-injection, injection, and post-injection phases of this project. Table 4

provides a listing of all the planned testing and monitoring activities during the injection phase, including frequencies and actual tests or technologies planned to be used. The injection wells and in-zone observation wells will be monitored to characterize reservoir pressure, monitor CO₂ transport response, and guide operational and regulatory decision-making. Figure 2 shows a simplified layout of the storage complex depicting the location of testing and monitoring equipment. The exact locations are tentative and may vary depending on field conditions.

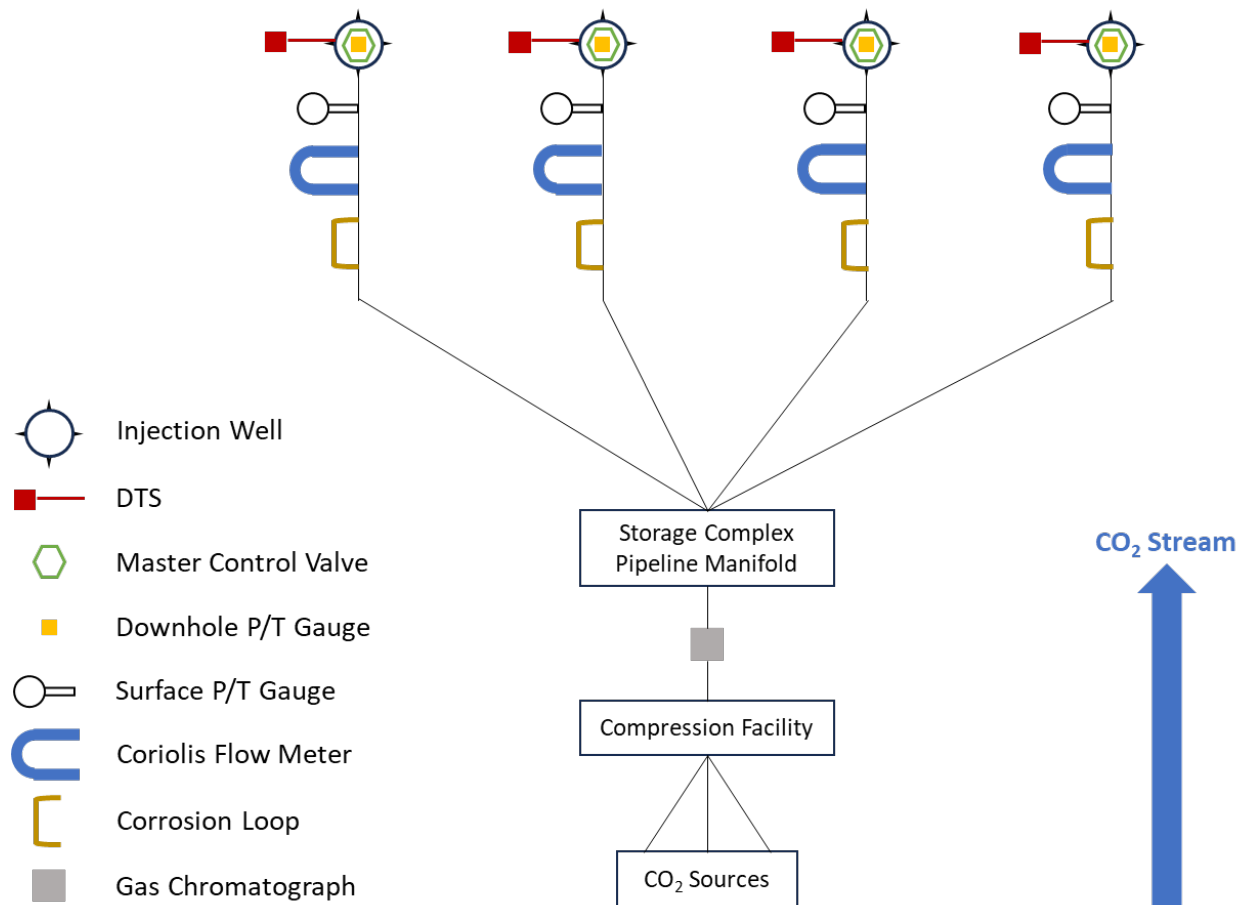

Figure 2: Simplified layout of storage complex depicting location of testing and monitoring equipment. The locations as depicted are tentative and may vary depending on field conditions.

The above-zone observation wells will monitor the first permeable zone above the primary confining zone for pressure, temperature, and fluid chemistry changes for early detection of containment loss. The in-zone observation wells, in combination with the above-zone observation wells, will provide the first indication of containment loss.

Tri-State CCS, LLC has implemented a well-based monitoring plan to track the CO₂ and pressure plume evolution to ensure protection of groundwater resources. Monitoring technology in injection and in-zone observation wells will help track the CO₂ and pressure plume front movement through time. The above-zone observation wells will be completed in the permeable unit of the Oriskany

Formation to detect physical and chemical changes in the formation water to ensure early detection of containment loss to protect USDWs. All observation wells will have direct monitoring of pressure in multiple zones.

Protection of USDWs, required by the EPA's UIC Class VI GS Rule (75 FR 77230), is a primary objective of the project's monitoring program as demonstrated by the two (2) above-zone, four (4) lowermost USDW, and up to four (4) shallow groundwater observation wells. Fluid samples will be collected from the wells in the Oriskany Formation (above-zone) and Mauch Chunk Group (lowermost USDW). The locations of these wells are designed to provide: 1) a thorough assessment of baseline conditions at the site, and 2) spatially distributed monitoring locations that can be routinely sampled throughout the life of the project.

The remainder of this page intentionally left blank.

Table 3: Testing and monitoring frequencies for all project phases.

Monitoring Category	Monitoring Parameter/Method		Baseline Frequency (1 year)	Injection Phase Frequency (30 years)	Post-Injection Frequency (50 years)
Monitoring Plan Update	Review Every 5 Years <i>Updated as Required</i>		N/A	Update As Required	Update As Required
CO ₂ Injection Stream Analysis	Chemical Characteristics		N/A	Continuous	N/A
	Physical Characteristics		N/A	Continuous	N/A
CO ₂ Injection Process Monitoring	Injection Rate		N/A	Continuous	N/A
	Injection Physical Characteristics		N/A	Continuous	N/A
	Annulus Pressure Monitoring		N/A	Continuous	N/A
	Annulus Volume Added		N/A	Continuous	N/A
Hydrogeologic Testing	Pressure Fall-Off Testing		1 Prior to Injection	3 Years After Injection, 1 Every 5 years After	N/A
Injection Well Mechanical Integrity Testing	<u>Internal Annulus</u>	Pressure Test	1 Prior to Injection	N/A	N/A
		Pressure Monitoring	N/A	Continuous	Continuous
	<u>External Temp.</u>	1) DTS <i>AND/OR</i> 2) Temp. Log 3) PNC Logging 4) Ultra Sonic CBL 5) Electromagnetic CI Logs	1 MIT Prior to Injection: 1 <i>OR</i> 2 <i>AND</i> 3-5	1 MIT Annually: 1 <i>OR one of</i> 2-5	N/A
Corrosion Monitoring	Corrosion Coupon Testing		N/A	Quarterly	N/A
Formation Water Quality and Geochemistry Monitoring	<i>Fluid Sampling and Analysis</i>	<i>Lowermost USDW</i>	Quarterly – 1 Year Prior to Injection	Quarterly for 1 st Year, Annually Thereafter.	Annually
		<i>Above-Zone</i>			
Direct Pressure Plume Monitoring	Wellhead P Gauges DH P Gauges		Continuous, After Well Construction	Continuous	Continuous
Indirect Plume Monitoring Techniques	<i>Fiber & Wireline</i>	DTS	1 Year Prior to Injection	Continuous	Continuous
		PNC Logging	1 Prior to Injection	3 Years After Injection, 1 Every 5 Years After ¹	1 Every 5 Years ¹
		Repeat 3D DAS VSP/ CSP/ Microseismic ²			

¹ Apart from injection wells, PNC logging or equivalent will only occur in wells with CO₂ breakthrough or wells with detected containment loss at the frequency specified in the table above. Based on actual wellbore/reservoir conditions post-breakthrough or contamination, the logging frequency may be modified in consultation with the UIC Program Director.

² DAS will be used for additional monitoring including potential repeat VSP/ CSP surveys or continuous microseismic monitoring based on additional site characterization. Final decision on additional monitoring will be made with consultation and approval of UIC Program Director.

Observation wells have been strategically placed to mitigate the highest risks to USDWs within the AoR. The in-zone wells (TR2-IOB-1, TR2-IOB-2, TR2-IOB-3, TR2-IOB-4) have been strategically placed to image the CO₂ plume and track the pressure front evolution. These wells have been placed within or close to the maximum CO₂ plume extent modeled 50 years post-injection and within the maximum pressure front extent and act as sentry wells bounding the CO₂ plume. Locations are subject to change based on data collected during the pre-operational testing phase. Monitoring data from these wells will be used to update and history match the pressure response in reservoir models. TR2-IOB-1 and TR2-IOB-2 wells will be placed to the north-northeast of TR2-1 and TR2-2 wells. TR2-IOB-3 will be placed to the southeast of TR2-3 injection well and TR2-IOB-4 will be placed northwest of TR2-4 injection well. Barring TR2-IOB-3, these observation wells are planned close to the maximum modeled extent of the CO₂ plume, 50 years post injection. These will allow Tri-State CCS, LLC to continuously monitor the injection zones at the edges of the modeled plume front to verify the pressures are acting as predicted and allow early detection of any CO₂ movement outside of the modeled plume extent.

The two above-zone observation wells (TR2-AOB-1, TR2-AOB-2) will monitor conditions in the first permeable zone above the primary confining zone to ensure containment of reservoir brine and CO₂. These wells are co-located in the TR2-1 and TR2-4 injection well pads. High pressure zones around the injection wells with natural (i.e., faults) or artificial penetrations pose the highest risk to containment and USDWs (Figure 3). Records of oil and gas wells that penetrate the confining zone are discussed in subsection 4.1 of the Area of Review and Corrective Action Plan. Tri-State CCS, LLC has placed the above-zone wells very close to the injection wells (TR2-1, TR2-4) for early detection of containment loss.

The four lowermost USDW observation wells (TR2-UOB-1, TR2-UOB-2, TR2-UOB-3, and TR2-UOB-4) are planned to be placed to ensure containment in the AoR and ultimately provide evidence for the non-endangerment demonstration required for site closure. Specifically, these wells will be placed on each injection well pad site to monitor the USDW directly above and around each injection well.

Up to four shallow groundwater observation wells (TR2-GW-1, TR2-GW-2, TR2-GW-3, and TR2-GW-4) will be placed at strategic locations as backup monitoring should Tri-State CCS, LLC need to monitor the shallow groundwater. Wells have not been placed at this time, but placement will consider potential contamination near the AoR, high-risk areas such as high pressures, and community concerns. Minimal surface disruption is anticipated by completing multiple project wells on a single well pad, where possible.

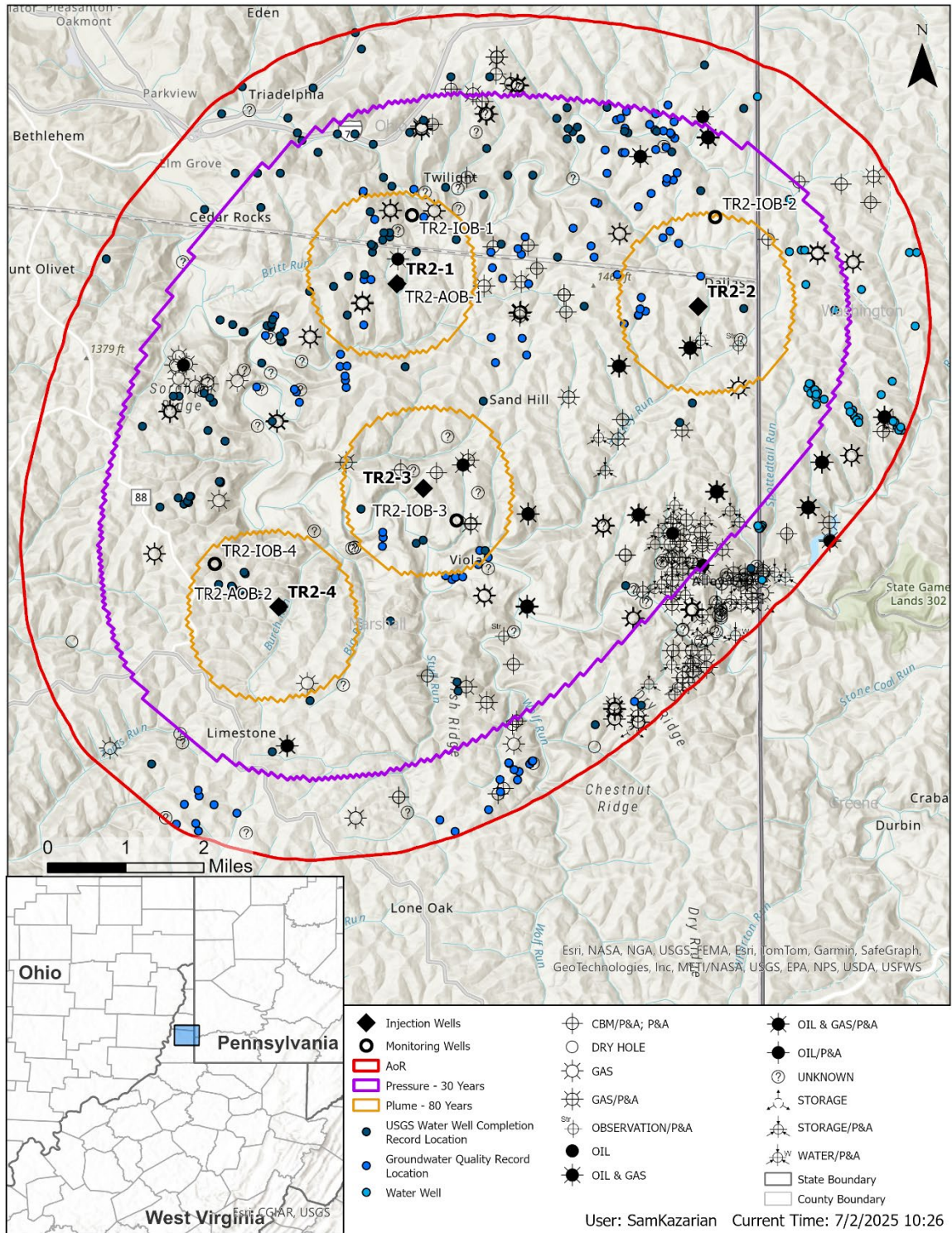

Figure 3: Locations of proposed injection and in-zone observation wells (TR2-IOB), oil and gas wells, water wells, the AoR, and the plume and pressure front boundaries. The above-zone observation (TR2-AOB), and lowermost USDW observation (TR2-UOB) wells are co-located on the injection well pads. No projected faults have been identified within the AoR boundary.

Table 4: Injection phase testing and monitoring frequencies and locations

Monitoring Parameter	Technology/Test	Injection Phase Frequency (30 years)	Location
Injectate Chemical Characteristics	1) Gas Chromatograph 2) Injectate Sampling & Analysis	1) Continuous 2) Annually	Prior to Injection Wells Manifold
Injection Rate	Mass Flow Meter	Continuous	Each Injection Well Pad (TR2-1, TR2-2, TR2-3, TR2-4)
Injection Physical Characteristics	1) P Gauges – Tubing 2) DH P Gauges	Continuous	TR2-1, TR2-2, TR2-3, TR2-4
Annulus Pressure Monitoring	P Gauge - Annulus	Continuous	TR2-1, TR2-2, TR2-3, TR2-4
Annulus Volume Added	Fluid Tank Volume Meter or suitable alternative	Continuous	Each Injection Well Pad (TR2-1, TR2-2, TR2-3, TR2-4)
Internal MIT	P Gauge - Annulus	Continuous	TR2-1, TR2-2, TR2-3, TR2-4
External MIT	DTS, <i>OR one of:</i> Temp. Log, PNC Log, Ultra Sonic CB Log, Electromagnetic CI Logs	1 MIT Annually	TR2-1, TR2-2, TR2-3, TR2-4; TR2-IOB-1, TR2-IOB-2, TR2-IOB-3, TR2-IOB-4
Corrosion	Coupon Analysis	Quarterly	Corrosion Loops at Each Injection Well (TR2-1, TR2-2, TR2-3, TR2-4)
Formation Water Quality & Geochemistry	1) Fluid S&A 2) DH P Gauges	1) Quarterly for 1 st Year, Then Annually ¹ 2) Continuous	TR2-AOB-1, TR2-AOB-2; TR2-UOB-1, TR2-UOB-2, TR2-UOB-3, TR2-UOB-4
Direct Pressure & Temperature Monitoring	1) P Gauges – Tubing 2) DH P Gauges 3) DTS ²	Continuous	TR2-1, TR2-2, TR2-3, TR2-4; TR2-IOB-1, TR2-IOB-2, TR2-IOB-3, TR2-IOB-4; TR2-AOB-1, TR2-AOB-2; TR2-UOB-1, TR2-UOB-2, TR2-UOB-3, TR2-UOB-4
Indirect CO ₂ Plume Monitoring Techniques	DTS	Continuous	TR2-1, TR2-2, TR2-3, TR2-4; TR2-IOB-1, TR2-IOB-2, TR2-IOB-3, TR2-IOB-4
	PNC Logging ³	3 Years After Injection, 1 Every 5 Years Thereafter	TR2-1, TR2-2, TR2-3, TR2-4; TR2-IOB-1, TR2-IOB-2, TR2-IOB-3, TR2-IOB-4
	Repeat 3D DAS VSP/ CSP, Microseismic ⁴		TBD
Hydrogeologic Testing	Pressure Fall-Off Testing		TR2-1, TR2-2, TR2-3, TR2-4

¹Sampling and analysis frequencies may be changed in consultation with the UIC Program Director based on project-specific benchmarks that will be defined from baseline monitoring data and/or injection phase monitoring data.

²Tri-State CCS, LLC does not plan to include a DTS fiber in the lowermost USDW observation wells.

³Apart from injection wells, PNC logging or equivalent will only occur in wells with CO₂ breakthrough or wells with detected containment loss at the frequency specified in the table above.

⁴Decisions on frequency and DAS based indirect plume monitoring plan will depend on data from the rest of the monitoring program and will be developed in consultation with the UIC Program Director. Similarly, decision on implementing microseismic monitoring will be based on observations from additional site characterization data.

2.4. Quality Assurance Procedures

A Quality Assurance and Surveillance Plan (QASP) for all testing and monitoring activities, required pursuant to 47 CSR 13-13.6.2.k, is provided as Appendix A to this Testing and Monitoring Plan.

2.5. Reporting Procedures

Tri-State CCS, LLC will report the results of all testing and monitoring activities to the UIC Program Director in compliance with the requirements under 47 CSR 13-13.6.3. The following reporting requirements apply to the project.

24-Hour Notification of an Event. Tri-State CCS, LLC will notify the UIC Program Director via phone as soon as practicable but within 24 hours of discovery of the following events (47 CSR 13-13.6.3.a.3):

- Any evidence that the injected CO₂ stream or associated pressure front may cause endangerment to a USDW;
- Any noncompliance with a permit condition, or malfunction of the injection system, which may cause fluid migration into or between USDWs;
- Any triggering of a shut-off system DH or at the surface; or
- Any failure to maintain mechanical integrity.

30-Day Notification of Planned Activity and Results Reporting. Tri-State CCS, LLC will provide written notice to the UIC Program Director at least 30 days in advance of the following activities at an injection well (47 CSR 13-13.6.3.a.4):

- Any planned well workover;
- Any planned stimulation activities, other than stimulation for formation testing conducted under the initial collection of geologic information; or
- Any other planned test of the injection well, including mechanical integrity testing by Tri-State CCS, LLC.

Within 30 Days of a well workover, MIT, or other injection well test, Tri-State CCS, LLC will submit the results to the UIC Program Director (47 CSR 13-13.6.3.a.2).

Semi-Annual Testing and Monitoring Report. Tri-State CCS, LLC will submit a semi-annual report to the UIC Program Director that will include the following (47 CSR 13-13.6.3.a.1):

- Any changes to the source as well as physical, chemical, and other relevant characteristics of the CO₂ stream;
- Monthly average, minimum, and maximum values for the operating injection pressure, injection flow rate, temperature, injection volume or mass, and annular pressure;
- Monthly annulus fluid volume added;

- Description of any event that significantly exceeds operating parameters for annulus or injection pressure;
- Description of any event that triggers a shutdown device (47 CSR 13.6.1.d) and the response taken;
- The monthly volume or mass of CO₂ injected over the current reporting period and cumulative volume, or mass of CO₂ injected since the start of injection;
- Any other data collected or results from the implementation of the Testing and Monitoring Plan (47 CSR 13-13.6.2).

Recordkeeping. Tri-State CCS, LLC will retain the following records, per 47 CSR 13-13.6.3.a.6, for the time specified:

- All site characterization data and data collected for the permit application will be retained throughout the life of the geologic sequestration project and for at least 10 years following site closure;
- Data on the nature and composition of all injected fluids will be retained for at least 10 years after site closure;
- Any monitoring data collected through the Testing and Monitoring Plan will be retained for at least 10 years after it is collected;
- Well plugging reports and all PISC data will be retained for at least 10 years after site closure.

In addition to these requirements, Tri-State CCS, LLC will follow any additional reporting and recordkeeping requirements as obligated by the UIC Program Director.

3. Carbon Dioxide Stream Analysis

Tri-State CCS, LLC will analyze the CO₂ stream during the injection phase to collect representative characteristic data on the chemical composition of the CO₂ stream, pursuant to 47 CSR 13-13.6.2.a. Tri-State CCS, LLC expects multiple sources of CO₂ from the region, with additional sources to be added throughout the life of the project. Each source will have a different gas stream composition based on the source's capture process and therefore the composition of the final injected gas stream will change depending on which sources are operational at any given time. As a result, the injectate stream composition will vary throughout the injection phase of the project. To account for this, Tri-State CCS, LLC plans to continuously monitor the CO₂ stream chemical composition to ensure it meets minimum composition specifications that will be refined when sources are finalized, and capture equipment is operational. The CO₂ stream coming into the storage site is expected to have a mol% CO₂ concentration of at least 95% with other chemical constituents as seen in Table 5.

A continuous gas chromatograph and sampling port will be installed downstream of all CO₂ sources and prior to the storage complex pipeline manifold to ensure the quality meets specification and that Tri-State CCS, LLC can isolate the delivery of the stream in the event it is out of specification (e.g., high water, H₂S, etc.).

3.1. Sampling Location and Frequency

Tri-State CCS, LLC will continuously analyze the CO₂ stream during the injection phase to collect representative chemical characteristic data. Baseline parameters will be established at the start of injection, and monitoring will occur continuously throughout the injection phase using a gas chromatograph. This chromatograph will be placed downstream of all CO₂ source points and prior to the storage complex pipeline manifold. Gas chromatograph sampling and monitoring will occur continuously at a minimum of 24-hour intervals. Tri-State CCS, LLC plans to conduct routine calibration of the gas chromatograph according to manufacturer specifications. To supplement this gas chromatograph monitoring, physical samples will also be collected from a sampling port annually for H₂S and total sulfur; this sampling port will be near the gas chromatograph downstream of all CO₂ sources and prior to the pipeline manifold. Tri-State CCS, LLC will report the results of the CO₂ stream analysis in the Semi-Annual Testing and Monitoring Reports.

In the event of unplanned disruptions to permitted injection activities that may affect the chemical composition of the final CO₂ stream, Tri-State CCS, LLC will increase the frequency of CO₂ stream reporting to the UIC Program Director to confirm there are no significant changes and injection is continuing to operate as permitted.

3.2. Analytical Parameters

Tri-State CCS, LLC will analyze the CO₂ stream for the constituents identified in Table 5 using a gas chromatograph and through physical sampling. The gas chromatograph will be installed to continuously detect CO₂ purity, total hydrocarbons, inert gases,. Gas chromatograph or sample bottles will be used for detecting hydrogen, alcohols, oxygen, carbon monoxide, and glycol. The list of parameters will be altered if analysis from the CO₂ stream demonstrates additional constituents to be considered. Any additional details concerning analysis of the CO₂ stream can be found in the Quality Assurance and Surveillance Plan (QASP), included as Appendix A. Amendments to this plan must be approved by the UIC Program Director.

3.3. Sampling Methods

The CO₂ stream will be sampled continuously at a minimum of 24-hour intervals with an on-site gas chromatograph. Physical samples will also be taken through a sampling port near the gas chromatograph downstream of all CO₂ sources and prior to the storage complex pipeline manifold. For more information refer to subsections 2.2 and 2.3 of the QASP.

The remainder of this page intentionally left blank.

Table 5: Summary of analytical parameters for CO₂ stream¹.

Component	Specification	Unit
Carbon Dioxide (CO ₂)	> 95	Mol%, dry
No free liquids		
Carbon Monoxide (CO)	< 1000	ppmv
Water (H ₂ O)	< 20	lb/MMSCF
Total Hydrocarbons	< 2	Mol%, dry
Amine	< 20	ppmv
Ammonia (NH ₃)	< 40	ppmv
Total Organic Compounds	< 50	ppmv
Hydrogen Sulfide (H ₂ S)	< 40	ppmv
SO _x	< 100	ppmv
Total Sulfur	< 100	ppmv
NO _x	< 100	ppmv
Glycol	< 1	ppmv
Hydrogen (H ₂)	< 1	Mol%
Inert Gasses (Non-Condensable)	< 5	Mol%, dry
Oxygen (O ₂)	< 100	ppmv
Particulate Matter	< 1	ppmw
Max Temperature	130	°F
Min Temperature	40	°F

¹This list is subject to change based on source injectate stream composition results.

4. Continuous Recording of Operational Parameters

Tri-State CCS, LLC will install and use continuous recording devices to monitor injection pressure, rate, and volume; the pressure on the annulus between the tubing and the long string casing; the annulus fluid volume added; and the temperature of the CO₂ stream pursuant to 47 CSR 13-13.6.1.d.1, and 13.6.2.b.

Tri-State CCS, LLC will monitor injection operations using a distributive process control system. The surface facility equipment and control system will limit the maximum instantaneous rate to 500 Mt/y or limit the wellhead pressures to 2,525 psig (TR2-1), 2,585 psig (TR2-2), 2,585 psig (TR2-3) and 2,545 psig (TR2-4). These pressures are below the regulatory requirement to not exceed 90% of the injection zone's fracture pressure (47 CSR 13-13.6.1.a). For the Lockport Dolomite Group and Medina Group injection depths, the maximum injection pressures are estimated to be 5,431 psig/5,674 psig for TR2-1, 5,581 psig/5,833 psig for TR2-2, 5,582 psig/5,830 psig for TR2-3, and 5,475 psig/5,719 psig for TR2-4. See Summary of Requirements for more details on operational conditions.

All critical system parameters (e.g., pressure, temperature, and flow rate) will have continuous electronic monitoring with signals transmitted back to a master control system. The system will automatically sound an alarm and shutdown operations should specified control parameters exceed their normal operating range at any time. Tri-State CCS, LLC supervisors and operations personnel will have the capability to monitor and control all operations remotely with this system.

4.1. Monitoring Location and Frequency

Tri-State CCS, LLC will perform the activities identified in Table 6 to monitor operational parameters. Surface and DH pressure and temperature instruments will be calibrated annually over the full operational range using ANSI or other recognized standards. DH pressure gauges shall have a drift stability of less than three (3) psi over the operational period of the instrument and an accuracy of \pm five (5) psi. Sampling rates will be at least once every five (5) seconds, except during reported non-routine operational conditions such as well workovers. Temperature sensors will be accurate to within one (1) degree Celsius. DH and surface pressure gauge specifications are described in more detail in subsection 1.4 of the QASP.

Injection rate (i.e., injection flow) will be monitored with Coriolis mass flow meters. The flow meters will be located on the injection well pad. The flow meter will be calibrated using accepted standards and be accurate to within \pm 0.1 percent. The flow meter will be calibrated for the entire expected range of flow rates. See subsection 1.4 of the QASP for additional details.

Table 6: Continuous recording sampling methods, locations, and frequencies

Parameter	Device(s)	Location	Min. Sampling Frequency (continuous inj./ shut-in)	Min. Recording Frequency (continuous inj./ shut-in)
Injection Pressure Monitoring	1) Tubing P Gauge 2) DH P Gauge ¹	1) TR2-1, TR2-2, TR2-3, TR2-4, TR2-IOB-1, TR2-IOB-2, TR2-IOB-3, TR2-IOB-4 2) TR2-1, TR2-2, TR2-3, TR2-4, TR2-IOB-1, TR2-IOB-2, TR2-IOB-3, TR2-IOB-4	5 sec. / 4 hours	5 mins. / 4 hours
Injection Rate	Coriolis Mass Flow Meter	TR2-1, TR2-2, TR2-3, TR2-4	5 sec. / 4 hours	5 mins. / 4 hours
Injection Volume	Coriolis Mass Flow Meter	TR2-1, TR2-2, TR2-3, TR2-4	5 sec. / 4 hours	5 mins. / 4 hours
Annular Pressure	Annular P Gauge	TR2-1, TR2-2, TR2-3, TR2-4	5 sec. / 4 hours	5 mins. / 4 hours
Annulus Fluid Volume	Fluid Tank Volume Meter	TR2-1, TR2-2, TR2-3, TR2-4	5 sec. / 4 hours	5 mins. / 4 hours
Injection Temperature Monitoring	DTS	TR2-1, TR2-2, TR2-IOB-1, TR2-IOB-2, TR2-IOB-3, TR2-IOB-4	10 min. / 12 hours	10 min. /12 hours

¹All DH gauges will be placed above packer and ported through it to the respective well monitoring zone. Additionally, individual injection zones will have independent DH monitoring gauges (see Table 1).

4.2. Injection Rate, Volume, and Pressure Monitoring

Tri-State CCS, LLC will continuously monitor injection rate, volume, and pressure for each injection well pursuant to 47 CSR 13-13.6.1.d.1, and 13.6.2.b. Storage site injection rate and

volume will be monitored using Coriolis mass flow meters that will be located at each well pad, immediately upstream of each injector wellhead, in accordance with manufacturer specifications. Individual Coriolis mass flow meters will be used to record each injection wells' injection rate and volume. Tri-State CCS, LLC will include measurements to account for flow rate of injected fluid, concentration of the fluid stream, injectate density, injectate temperature, and energy inputs required for operation. Flow meters will be temperature and pressure compensated and calibrated according to manufacturer specifications. Flow rate data will be used to determine the cumulative mass of CO₂ injected and to confirm compliance with operational requirements of the Class VI UIC permit.

Injection pressure will be continuously monitored using wellhead and DH pressure gauges. Each injection well will be equipped with permanent DH pressure gauges that will continuously monitor both injection zone (Lockport Dolomite Group and Medina Group) pressures to ensure they do not exceed 90 percent of the reservoir fracture pressure as required by 47 CSR 13-13.6.1.a, and to ensure compliance with operating conditions. Additionally, each injection well will be equipped with a wellhead pressure logger that will ensure Tri-State CCS, LLC maintains surface pressures below the maximum allowable pressure for each well. This pressure limit is equal to the top perforation or completion depth, in true vertical depth (TVD), multiplied by the difference between the injection gradient and the injectate fluid gradient. Surface tubing pressure will be kept below 2,525 psig (TR2-1), 2,585 psig (TR2-2), 2,585 psig (TR2-3), and 2,545 psig (TR2-4), respectively.

4.3. Annulus Pressure & Fluid Volume Monitoring

Tri-State CCS, LLC will use the procedure below to monitor annular pressure to limit the potential for any unpermitted fluid movement into or out of the injection well annulus:

- The annulus between the tubing and the long string of casing will be filled with brine. Brine will meet specified parameters such as a brine specific gravity, brine density, and annulus hydrostatic gradient. The brine may contain a corrosion inhibitor. The exact brine composition will be finalized after the well has been drilled.
- The surface annulus pressure will be kept within a range from 100 psig to 2,625 psig for TR2-1, 2,685 psig for TR2-2, 2,685 psig for TR2-3, and 2,645 psig for TR2-4.
- During periods of well shut down, the surface annulus pressure will be kept at a minimum pressure to maintain a pressure differential of an estimated 100 psi between the annular fluid directly above (higher pressure) and below (lower pressure) the injection tubing packer.
- The pressure within the annular space, over the interval above the packer to the confining layer, will always be greater than the pressure of the injection zone formations.
- The pressure in the annular space directly above the packer will be maintained at least 100 psi higher than the adjacent tubing pressure during injection.

Figure 4 shows the process instrument diagram used for injection well annulus protection systems. The annular monitoring system will consist of a continuous annular pressure gauge, a pressurized annulus fluid reservoir (annulus head tank), pressure regulators, and tank fluid level indicator. The annulus system will maintain annulus pressure by controlling the pressure on the annulus head tank using compressed nitrogen.

During injection, the annular pressure between the tubing and the long-string casing will be maintained at a higher pressure than the injection pressure at bottom hole conditions, and will be monitored by the Tri-State CCS, LLC control system gauges. The annulus head tank pressure will be controlled by pressure regulators or pumps; one set of regulators or pumps will be used to maintain pressure above injection pressure, if needed by adding compressed nitrogen or CO₂, and the other set will be used to relieve pressure, if needed, by venting gas or fluid from the annulus head tank. Any changes to the composition of annular fluid will be submitted to the UIC Program Director for approval.

If system communication were to be lost for greater than 60 minutes, project personnel will observe and monitor manual gauges in the field every eight hours or once per shift for both wellhead surface pressure and annulus pressure, while also recording hard copies of the data until communication is restored. Average annular pressure, annulus tank fluid level, and volume of fluid added or removed from the system will be recorded daily and reported as monthly averages in the Semi-Annual Testing and Monitoring Report.

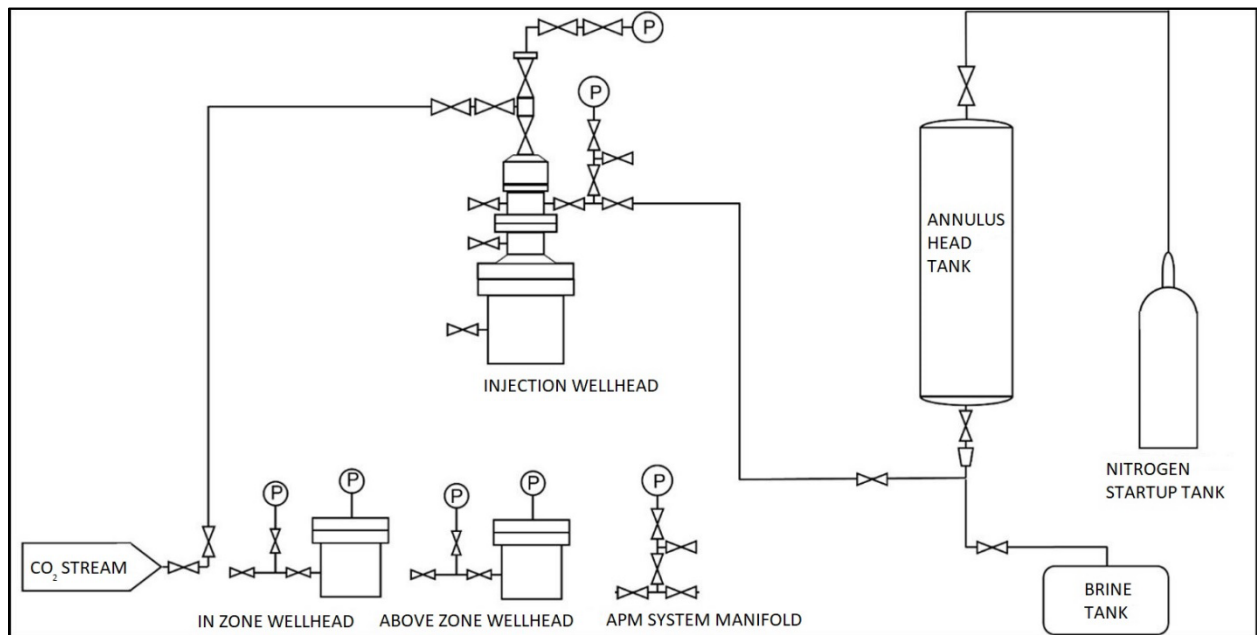

Figure 4: Annular monitoring system.

4.4. Injection Temperature Monitoring

Tri-State CCS, LLC will continuously monitor injection temperature at the surface and DH for each injection well. The wellhead temperature logger will also continuously measure and record wellhead temperature and be used as a backup should the DTS fail. Tri-State CCS, LLC will supply DH temperature measurements using DTS fiber optic cable.

In-well pressure and temperature measurements will be taken using permanent DH gauges. Specifically, the two DH injection zones (Lockport Dolomite Group and Medina Group) will be

monitored by independent gauges. Fiber optic technology will be implemented in the injection and observation wells. DTS fiber optic wire will be run from the surface to the wells' total depth (TD). This technology will continuously measure the temperature in the formations outside the casing throughout the entire well column.

5. Corrosion Monitoring

To meet the requirements of 47 CSR 13-13.6.2.c, Tri-State CCS, LLC will monitor well materials during the operation period for loss of mass, thickness, cracking, pitting, and other signs of corrosion to ensure that the well components meet the minimum standards for material strength and performance.

Tri-State CCS, LLC will monitor corrosion using corrosion coupons and collect samples according to the description below.

5.1. Monitoring Location and Frequency

Corrosion monitoring will occur on a quarterly basis during the injection phase, based on the date of issuance of the authorization to inject. The corrosion monitoring systems will be located upstream of the wellhead, prior to the Coriolis mass flow meters, and downstream of the injection well control valve (Figure 2). This system will allow for continuation of CO₂ injection during sample removal.

5.2. Sample Description

Samples of materials used in the construction of compression equipment, pipeline, and any wells which encounter CO₂ will be included in the corrosion monitoring program. The samples will be comprised of those items listed in Table 7. Each coupon will be weighed, measured, and photographed prior to initial exposure.

Table 7: List of equipment coupons with material of construction

Equipment Coupon		Material of Construction
Pipeline		API 5L X60, API 5L X65 PSL2 carbon steel
Long String Casing	Non-Injection Zones ¹	26 lb/ft, L-80, Premium Connection
Long String Casing	Injection Zones ¹	26 lb/ft, 22Cr-110, Premium Connection
Injection Tubing		9.2 lb/ft, 22 Cr-110, Premium Connection
Wellhead		Carbon/low alloy steel or Stainless steel or CRA ²
Packers		22 Cr-110 or higher CRA (TBD) ³

¹ For exact depth, refer to the well construction details.

² Corrosion Resistant Alloy

³ Exact grade of corrosion Resistant Alloy will be finalized later after additional characterization data from CarbonSAFE stratigraphic test well planned in the region.

5.3. Monitoring Details

Tri-State CCS, LLC will monitor for corrosion using corrosion coupons in a closed loop system. Each sample will be attached to an individual holder and then inserted into a flow-through pipe arrangement (Figure 5) attached to the pipeline. The corrosion monitoring systems will be located upstream of the wellhead and downstream of the injection well control valve (Figure 2). The corrosion loop system routes a parallel stream of high-pressure CO₂ from the pipeline through the corrosion monitoring system and then back into a lower pressure point upstream in the compression system. The loop will allow for corrosion inspection and injection to occur simultaneously. The corrosion equipment is placed close to the wellhead prior to the Coriolis mass flow meter to provide representative exposure of the CO₂ composition, temperature, and pressures that will be observed at the wellhead and injection tubing.

Corrosion coupons will be handled and evaluated for corrosion using the NACE RP0775-2018 (NACE, 2018) standard or a similarly accepted standard practice for preparing, cleaning, and evaluating corrosion test specimens. The coupons will be photographed, visually inspected (under minimum of 10x power), dimensionally measured to within 0.0001 inch, and weighted to within 0.0001 gram. The corrosion rate will be calculated as the weight loss during the exposure period divided by the duration of exposure (i.e., weight loss method). Corrosion monitoring is implemented in this project as a loss of containment prevention measure.

Casing and tubing will be evaluated for corrosion on an as-needed basis by running wireline casing inspection logs. Furthermore, wireline tools can be lowered into the well to directly measure properties of the well tubulars that indicate corrosion. These tools will provide circumferential images with high resolution such that pitting depths, due to corrosion, can often be accurately measured. The different types of logs that may be used to monitor and assess the condition of well tubing and casing include:

- Mechanical Casing Evaluation Tools: referred to as calipers, these tools have multiple articulated arms attached to the tool that measure the inner diameter of the tubular as the caliper is raised or lowered throughout the well.
- Ultrasonic Tools: these tools measure wall thickness in addition to the inner diameter of the well tubular and can also provide information about the outer surface of the casing or tubing.
- Electromagnetic Tools: these tools are capable of distinguishing between internal and external corrosion effects using variances in the magnetic flux of the tubular being investigated.

The remainder of this page intentionally left blank.

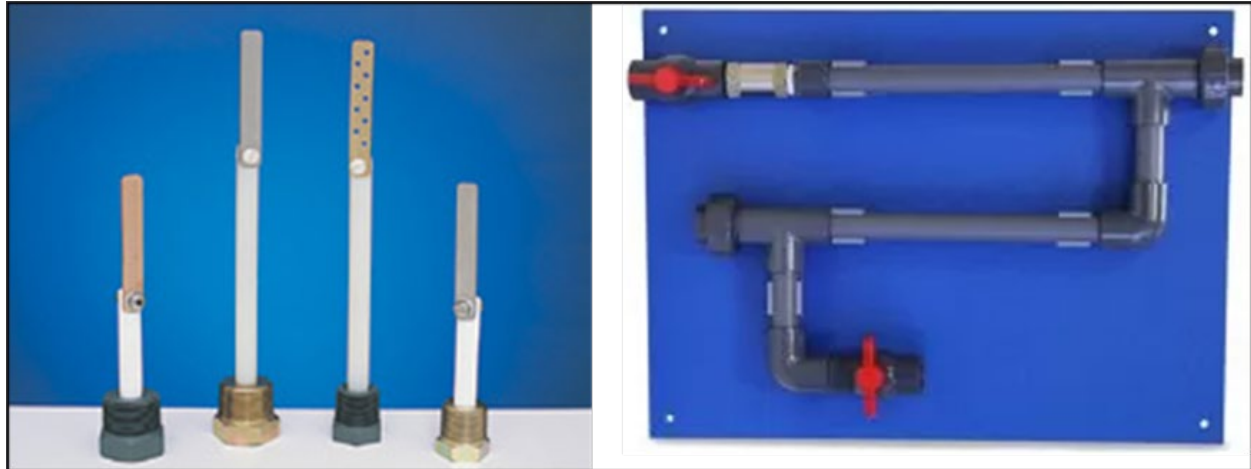

Figure 5: (Left) Example of corrosion coupon holders. (Right) Flow through pipe arrangement example.

6. Above Confining Zone Monitoring

Tri-State CCS, LLC will monitor formation water quality and geochemistry in the first permeable unit above the confining zone and lowermost USDW during the pre-injection and injection phases pursuant to 47 CSR 13-13.6.2.d. During the post-injection phase of the project, formation water quality and geochemistry will be monitored in only the first permeable unit above the confining zone and the lowermost USDW. Formation water geochemistry monitoring will be conducted using direct fluid sampling and analysis. Formation pressure will be monitored directly using DH pressure gauges.

Baseline monitoring will be conducted in all project wells completed in the Lockport Dolomite and Medina Groups (primary injection zones), the Oriskany Formation (first permeable unit above the confining zone), and the Mauch Chunk Group (lowermost USDW) to understand formation and formation water fluid chemistry and quality prior to injection (Table 2). This section describes formation water monitoring during the injection phase of the project with a focus on the following zones:

- Oriskany Formation (first permeable zone above the Salina Group confining zone); and
- Mauch Chunk Group (lowermost USDW).

During the injection phase of the project, routine formation water quality monitoring will occur in all above-zone and lowermost USDW observation wells. The DH pressure behavior in the in-zone observations wells, in addition to the monitoring results from above-zone observation wells in the first permeable unit (Oriskany Formation) above the upper confining zones, will provide the first evidence of any loss of containment. Statistical approaches such as outlier testing will be used to identify deviations from the baseline. If a loss of containment is detected and verified, a modeling evaluation of any observed injectate migration above the confining zone will be used to evaluate the magnitude of containment loss and generate bounding predictions regarding anticipated impacts on shallower reservoirs, USDW aquifers, and ecology.

6.1. Monitoring Location and Frequency

The proposed locations of the two above-zone (TR2-AOB-1, TR2-AOB-2) and four in-zone (TR2-IOB-1, TR2-IOB-2, TR2-IOB-3, and TR2-IOB-4) observation wells are spatially displayed in Figure 3 and Table 1. The locations of the four lowermost USDW (TR2-UOB-1, TR2-UOB-2, TR2-UOB-3, TR2-UOB-4) observation wells, as well as that of the planned shallow groundwater observation wells (Table 1) are tentative and will be finalized as the project progresses. The identified locations are subject to change based on new information from planned testing activities and subsequent changes in the current monitoring plan. The proposed monitoring technologies, locations, depth intervals, and frequencies for geochemical monitoring are displayed in Table 8 below.

Table 8: Monitoring geochemical and physical changes.

Target Formation	Monitoring Activity	Monitoring Location(s)	Spatial Coverage ³			Frequency
Mauch Chunk Group (Lowermost USDW)	<i>Geochemical Monitoring:</i> Direct Fluid Sampling	Lowermost USDW observation wells [TR2-UOB-1, TR2-UOB-2, TR2-UOB-3, TR2-UOB-4]	4 Well Locations			Quarterly for first year ¹ , annually thereafter ² .
	<i>Physical Monitoring:</i> DH P Gauges		Vertical (ft. MD): TR2-UOB-1: ~254 TR2-UOB-2: ~267 TR2-UOB-3: ~333 TR2-UOB-4: ~291			
Oriskany Formation (First permeable unit over confining zone)	<i>Geochemical Monitoring:</i> Direct Fluid Sampling	Above-zone observation well [TR2-AOB-1, TR2-AOB-2]	2 Well Locations			Quarterly for first year ¹ , annually thereafter ² .
	<i>Physical Monitoring:</i> DH P Gauges		Vertical (ft. MD): TR2-AOB-1: ~6,623 TR2-AOB-2: ~6,656			
Lockport Dolomite and Medina Groups (Injection Interval)	<i>Physical Monitoring:</i> DH P Gauges	In-Zone Observation Wells [TR2-IOB-1, TR2-IOB-2, TR2-IOB-3, TR2-IOB-4]	4 Well Locations			Continuous
			Vertical (ft. MD):			
			Well	Lockport Group	Medina Group	
			TR1-IOB-1	~ 8,513	~ 9,320	
			TR1-IOB-2	~ 8,658	~ 9,479	
			TR1-IOB-3	~ 8,571	~ 9,390	
			TR1-IOB-4	~ 8,580	~ 9,376	

¹Quarterly sampling will take place every 3 months of the first year based on the date of authorization of injection.

²Annual sampling will occur up to 45 days before the anniversary date of authorization of injection each year.

³Actual depths will depend on monitoring requirements.

6.2. Analytical Parameters

Fluid samples collected from the specified intervals will be analyzed for geochemical parameters listed in Table 9. Acquired groundwater monitoring data will be periodically evaluated throughout the injection phase, and if listed parameters are determined to have a non-significant impact on meeting project monitoring objectives, they will be removed from the groundwater geochemistry analysis strategy. Additionally, the monitored parameters will be reevaluated and updated as needed if new sources of CO₂ are added to the injection stream. Samples from the shallow groundwater observation wells will be analyzed for groundwater geochemistry during baseline testing and monitoring. These wells will not be sampled and analyzed during the injection phase but may be used to provide additional evidence for groundwater protection should Tri-State CCS, LLC or the UIC Program Director deem it necessary.

The remainder of this page intentionally left blank.

Table 9: Summary of analytical and field parameters for ground water samples.

Parameters	Analytical Methods
Shallow Groundwater (Pennsylvanian) Observation Wells	
Cations: Al, Ba, Mn, As, Cd, Cr, Cu, Pb, Sb, Se, and Tl	ICP-MS, EPA Method 6020B (2014a) or EPA Method 200.8 (1994a)
Cations: Ca, Fe, K, Mg, Na, and Si	ICP-OES, EPA Method 6010D (2014b) or EPA Method 200.7 (1994b)
Anions: Br, Cl, F, NO ₃ , and SO ₄	Ion Chromatography, EPA Method 300.0 (1993)
Dissolved CO ₂ Total Dissolved Solids Water Density Alkalinity pH (field) Specific conductance (field) Temperature (field)	Coulometric titration, ASTM D513-16 (ASTM, 2016) Gravimetry, APHA 2540C (1997) Oscillating body method APHA 2320B (1997) EPA 150.1 (1982) APHA 2510 (1997) Thermocouple
Lowermost USDW (Mauch Chunk Group), and Above-Zone (Oriskany Formation) Observation Wells	
Cations: Al, Ba, Mn, As, Cd, Cr, Cu, Pb, Sb, Se, and Tl	ICP-MS, EPA Method 6020B (2014a) or EPA Method 200.8 (1994a)
Cations: Ca, Fe, K, Mg, Na, and Si	ICP-OES, EPA Method 6010D (2014b) or EPA Method 200.7 (1994b)
Anions: Br, Cl, F, NO ₃ , and SO ₄	Ion Chromatography, EPA Method 300.0 (1993)
Isotopes: δ ¹³ C of DIC	Isotope ratio mass spectrometry
Dissolved CO ₂ Total Dissolved Solids Water Density Alkalinity pH (field) Specific conductance (field) Temperature (field)	Coulometric titration, ASTM D513-16 (ASTM, 2016) Gravimetry, APHA 2540C (1997) Oscillating body method APHA 2320B (1997) EPA 150.1 (1982) APHA 2510 (1997) Thermocouple

Abbreviations: ICP=inductively coupled plasma; MS= mass spectrometry; OES = Optical emission spectrometry; GC-P=Gas Chromatography-Pyrolysis.

6.3. Sampling Methods

Groundwater sampling, sample preservation, and quality assurance will be conducted in accordance with methods/procedures described in subsection 2.2 of the QASP.

6.4. Laboratory to be Used/Chain of Custody Procedures

Sample handling and chain of custody will be conducted in accordance with procedures described in subsection 2.3 of the QASP.

7. Mechanical Integrity Testing

Tri-State CCS, LLC is committed to maintaining injection well mechanical integrity throughout the life of the project. A well has mechanical integrity if:

- There is no internal leak in the casing, tubing, or packer;
- There is no significant external fluid movement out of the sequestration zone through channels adjacent to the wellbore; and
- Corrosion monitoring, pursuant to Subsection 47 CSR 13-13.6.2.c, reveals no loss of mass or thickness that may indicate the deterioration of well components (casing, tubing, or packer).

Tri-State CCS, LLC will demonstrate internal and external mechanical integrity prior to injection (47 CSR 13-13.5), during the injection phase (47 CSR 13-13.6.2), and prior to well plugging after injection has ceased (47 CSR 13-13.4). For more information on testing details and locations prior to injection, please refer to subsection 2.2 of this plan and the Pre-Operational Testing Program.

Internal mechanical integrity will be demonstrated with an initial annulus pressure test and thereafter with continuous tubing and annulus monitoring. External mechanical integrity will be demonstrated with DTS fiber optic cables in all injection and in-zone observation wells. More details on these methods and their frequencies are discussed in the following subsections and in Table 10. If the DTS fiber optic cables fail, other methods listed in Table 3 will be used to demonstrate external mechanical integrity.

Tri-State CCS, LLC will comply with notification and reporting requirements described in subsection 2.5 above.

The gauges and meters used for mechanical integrity testing will be calibrated according to the manufacturer's specifications. Should loss of mechanical integrity be demonstrated through monitoring, Tri-State CCS, LLC will take necessary steps to determine whether there may have been a release of the injected CO₂ stream or formation fluids into any unauthorized zone. If there is substantial endangerment to public health or the environment from any fluid movement out of the intended storage complex, Tri-State CCS, LLC will implement the Emergency and Remedial Response Plan (ERRP; 47 CSR 13-13.7), follow reporting requirements of 47 CSR 13-13.6.3 (see subsection 2.5 above), and restore and demonstrate mechanical integrity prior to resuming injection or plugging of the well. In the case of unscheduled or remedial well activity, the UIC Program Director will receive a remediation plan that includes MIT activity to demonstrate well integrity following intervention per the ERRP (47 CSR 13-13.7).

If a well loses mechanical integrity prior to the next scheduled test date, the well will be repaired and retested within 30 days of losing mechanical integrity. In addition, Tri-State CCS, LLC will, in the next Semi-Annual Testing and Monitoring Report, document the type of failure, the cause, the required repairs, and conduct a new test of mechanical integrity following the requirements of section 47 CSR 13-13.6.1.e.

7.1. Testing Location and Frequency

Prior to injection, internal mechanical integrity will be demonstrated in all injection wells with an initial annulus pressure test (47 CSR 13-13.5.1.d). Following this initial pressure test and during the injection phase, Tri-State CCS, LLC will demonstrate internal mechanical integrity in all injection wells by continuously monitoring the injection tubing and annular space pursuant to 47 CSR 13-13.6.1, and 47 CSR 13-13.6.2. External mechanical integrity will be demonstrated with DTS fiber optic cables in all injection and in-zone observation wells. DTS fiber optic cables allow for continuous monitoring and will demonstrate external mechanical integrity prior to injection (47 CSR 13-13.5), during the injection phase (47 CSR 13-13.6.2), and prior to well plugging after injection has ceased (47 CSR 13-13.4).

Table 10 summarizes internal and external MIT methods, locations, and frequency. For more information on testing details and locations prior to injection, refer to subsection 2.2 of this plan and the Pre-Operational Testing Program. If the DTS fiber optic cables fail, other methods listed in Table 3 will be used to demonstrate external mechanical integrity.

Table 10: Mechanical integrity testing (MIT) location and frequency.

Monitoring Category	Monitoring Method	Frequency	Location
Internal MIT	1) Annulus Pressure Test 2) Annulus Pressure Monitoring	1) Prior to Injection 2) Continuous	TR2-1, TR2-2, TR2-3, TR2-4
External MIT	DTS	Continuous	Depths: <i>Surface to Casing TD (Cemented Casing String)</i> TR2-1, TR2-2, TR2-3, TR2-4, TR2-IOB-1, TR2-IOB-2, TR2-IOB-3, TR2-IOB-4

7.2. Testing Details

Internal mechanical integrity will first be demonstrated through an initial annulus pressure test (47 CSR 13-13.5). The standard annular pressure test (SAPT) will include pressurizing the annulus to a specified level and observing its pressure for an established period (EPA, 2008; EPA, 2013). A loss of mechanical integrity can then be detected by changes in pressure which indicates the annular space is not sealed and is communicating with the tubing. As an example, as per EPA (2008), loss of mechanical integrity, or a failed test, is one where there is a pressure loss of 3% or more within a 60-minute test period (*EPA Region 5 Determination of the Mechanical Integrity of Injection Wells*). This test is also discussed in subsection 2.5 of the Pre-Operational Testing Program. The actual test procedure, including the pressure loss limits and test duration, will be determined in consultation with the UIC Program Director before the test. Following the initial annulus pressure test, injection pressure, rate, and volume along with annulus pressure and volume will be continuously monitored throughout the injection phase and prior to well plugging to demonstrate internal mechanical integrity pursuant to 47 CSR 13-13.6.1, 13.6.2, and 13.4. Specific

details for continuous monitoring of the CO₂ stream and annulus are discussed in subsections 3 and 4.3, respectively, of this plan.

External mechanical integrity will be demonstrated with DTS fiber optic cables that run throughout each injection and in-zone observation well. External mechanical integrity tests are designed to detect fluids that have escaped from the wellbore and could migrate into USDWs (EPA, 2013). The DTS fiber optic cables can detect fluid movement along channels adjacent to the wellbore in real-time by continuously monitoring the temperature from surface to total depth. Prior to injection, a temperature baseline profile will be recorded to identify injection phase temperature anomalies indicative of fluid flow beyond, and leaks into, the casing. These continuous DTS fiber optic measurements can therefore demonstrate external mechanical integrity and replace the need for yearly temperature logging (except for calibration) while satisfying 47 CSR 13-13.5, 13.6.1, 13.6.2, and 13.4.

Both wellhead and DH pressure gauges will meet or exceed ASME B 40.1 Class 2A (ASME, 2013) (0.5% accuracy across full range). Wellhead and DH gauge specifications are described in detail in subsection 1.4 of the QASP.

8. Pressure Fall-Off Testing

Tri-State CCS, LLC will perform pressure fall-off testing of the injection wells pursuant to 47 CSR 13-13.6.2.f and will use the *EPA Region 5 Planning, Executing, and Reporting Pressure Transient Tests* (EPA, 1998). Pressure fall-off tests are designed to determine if reservoir pressures are tracking predicted pressures and modeling inputs. The results of pressure fall-off tests will confirm site characterization information, inform AoR reevaluations, and verify the project is operating properly, and the injection zone is responding as predicted.

8.1. Testing Location and Frequency

The minimum frequency at which Tri-State CCS, LLC will perform pressure fall-off testing is as follows:

- Prior to injection (baseline); and
- Three years from the start of injection and every five years thereafter until well plugging and abandonment.

Pressure fall-off tests will be conducted in every injection well during periodic well workovers, or at a minimum three years after injection and once every five years thereafter, to calculate the changes in reservoir injectivity.

Table 11: Injection phase pressure fall-off testing frequency and schedule.

Monitoring Method	Frequency	Location
Pressure fall-off testing	1 prior to injection, 1 three years from the start of injection, and 1 every five years thereafter until well abandonment	TR2-1, TR2-2, TR2-3, TR2-4

8.2. Testing Details

A pressure fall-off test includes a period of injection followed by a period of no-injection or shut-in. Normal injection with the project's CO₂ stream will be used during the injection period preceding the shut-in portion of the fall-off tests. This injection period should be at least 150% of the expected fall-off period; however, several weeks or even months of injection prior to the fall-off test will likely be part of the pre-shut-in injection period and subsequent analysis (*EPA Region 5 Planning, Executing, and Reporting Pressure Transient Tests (EPA, 1998)*). Prior to the fall-off test, this rate will be maintained, i.e., stabilized in accordance with the program design. If this rate causes relatively large changes in bottomhole pressure, the rate may be decreased. Injection rates on a well-by-well basis will be continuously recorded and employed in the analysis of the continuously recorded subsurface pressure data. Following the injection period, Tri-State CCS, LLC and/or a third-party vendor will shut-in each well at the wellhead instantaneously in coordination with the injection compression facility operators. The shut-in period of the fall-off test should be an appropriate length to allow adequate pressure transient data to be collected for calculating the average pressure. Tri-State CCS, LLC will comply with notification and reporting requirements described in subsection 2.5 above, reporting pressure fall-off data and interpretation of the reservoir ambient pressure following the test.

All data will be measured using permanent DH pressure gauges, along with wellhead sensors, so testing durations can be determined in real-time. Because surface readout will be used and DH recording memory restrictions will be eliminated, data will be collected at intervals of five seconds or less for the duration of the test. Both wellhead and DH pressure gauges will meet or exceed ASME B 40.1 Class 2A (ASME, 2013) (0.5% accuracy across full range). The wellhead pressure gauge range will be 0-15,000 psi. The DH gauge range will be 200-10,000 psi for pressure. Wellhead and DH gauge specifications are described in detail in subsection 1.4 of the QASP.

9. Carbon Dioxide Plume and Pressure Front Tracking

Tri-State CCS, LLC will implement indirect methods (Table 12) to track the CO₂ plume evolution and direct methods (Table 13) to track the pressure front propagation at specified locations and frequencies, per 47 CSR 13-13.6.2.g. This plan is designed to monitor the free-phase CO₂ plume location, thickness, and saturation; track the pressure development within the storage complex over time; validate computational modeling results; and demonstrate that operations are not leading to reservoir CO₂ or brine containment risks.

Direct pressure monitoring will be implemented to track the pressure front evolution throughout the project's life using permanent DH and surface pressure gauges. Gauges ported in the two reservoirs (Lockport Dolomite and Medina Groups) will record corresponding reservoir pressures and allow for better pressure front modeling. Pressure gauges ported to monitor the first permeable zone (Oriskany Formation) or lowermost USDW (Mauch Chunk Group) will allow Tri-State CCS, LLC to monitor any anomalous pressure changes above the primary confining zone for early detection of containment loss.

Monitoring locations relative to the predicted location of the CO₂ plume within the AoR at five and ten-year intervals throughout the injection phase are shown in Figure 6. Two types of pressure front and CO₂ plume monitoring will occur at the project: 1) plume monitoring within the reservoir, and 2) containment confirmation above the primary confining zone. Direct pressure measurements will be implemented for pressure front tracking, and several indirect methods will be employed to track the CO₂ plume migration.

DTS technology will be run on the outside of the long string casing along the entirety of the wellbore and will record temperature measurements that can reveal the vertical location of near wellbore CO₂. This indirect CO₂ monitoring technology will be installed during well construction and will operate continuously during the baseline, injection, and post-injection periods. In practice, DTS systems typically provide temperature measurements at 1-meter (m) spacing along the cable.

PNC logging wireline tools will be run to monitor the vertical saturations and profile of CO₂ within formations of interest at observation well locations as required. In case of DTS failure, Tri-State CCS, LLC in consultation with the UIC Program Director will develop an alternate testing plan, such as an alternate PNC logging program at the observation wells.

The remainder of this page intentionally left blank.

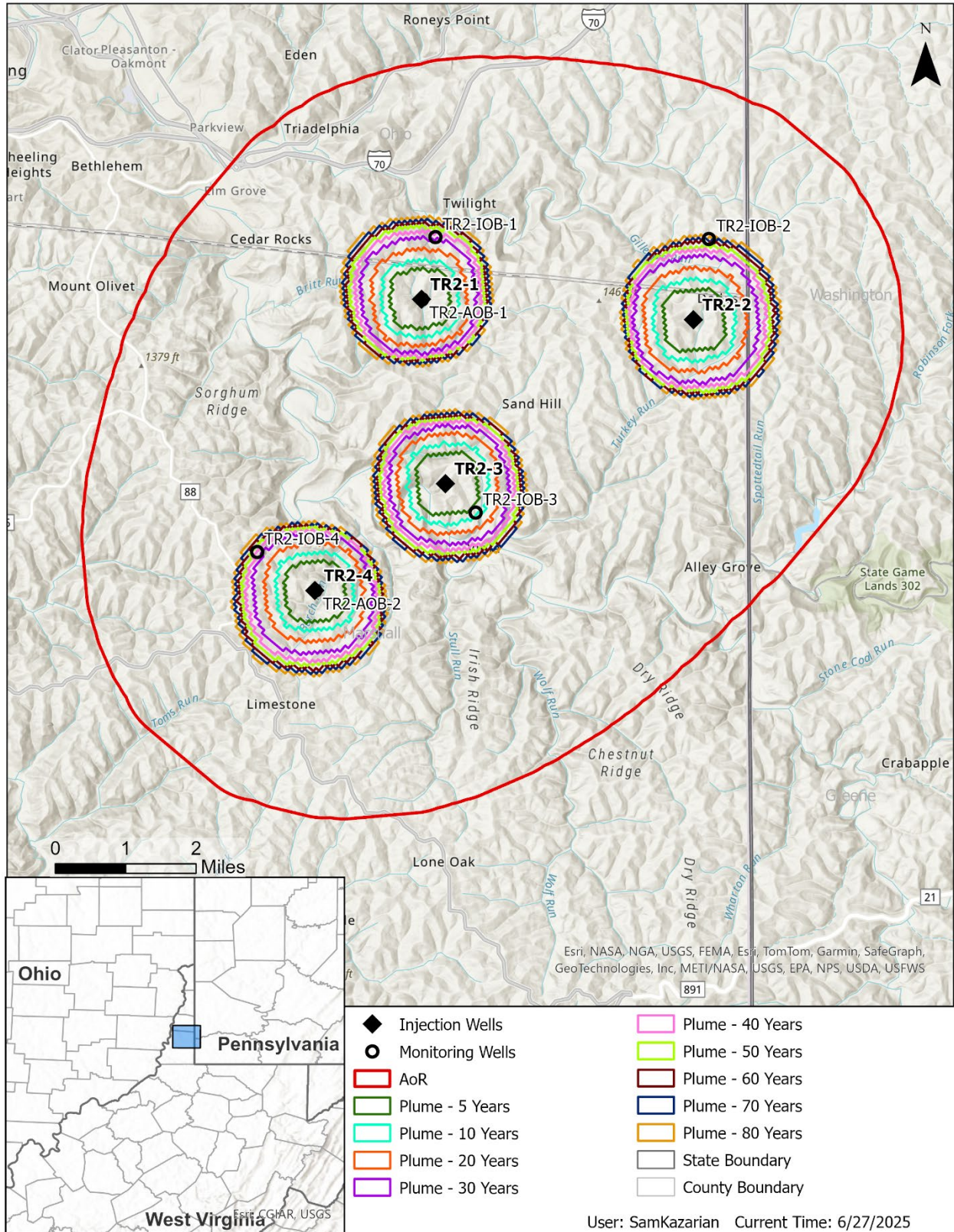

Figure 6: Project CO₂ plume evolution map after 30 years of injection and 50 years post-injection.

9.1. Plume Monitoring Location and Frequency

As summarized in Table 12 below, Tri-State CCS, LLC will utilize a combination of indirect methods to detect, track, and monitor the CO₂ plume during the injection phase. Locations of the observation wells with respect to the plume extents throughout the project are represented in Figure 6. Locations are subject to change based on final site characterization and land access agreements.

DTS will be installed in all injection wells (TR2-1, TR2-2, TR2-3, and TR2-4) and in-zone observation wells (TR2-IOB-1, TR2-IOB-2, TR2-IOB-3, and TR2-IOB-4) and will continuously monitor temperature changes along the injection wellbore to detect units within the reservoir taking CO₂ and to detect any potential CO₂ breakthrough at in-zone observation wells. Repeat PNC logging will be run in each injection well three years after injection begins, every five years thereafter during the injection period, and before the plugging and abandonment of any injection well or AoR re-evaluation. For the in-zone (TR2-IOB-1, TR2-IOB-2, TR2-IOB-3, TR2-IOB-4), above-zone (TR2-AOB-1, TR2-AOB-2), and lowermost USDW observation wells (TR2-UOB-1, TR2-UOB-2, TR2-UOB-3, TR2-UOB-4), repeat PNC logging will only occur if containment loss is detected and will then be used as a containment verification technology. DAS fiber optic cable will be installed in some of the injection and in-zone observation wells for repeat (time lapse) seismic profile surveys.

9.2. Plume Monitoring Details

The two technologies mentioned above will allow Tri-State CCS, LLC to monitor the CO₂ plume evolution within the reservoir and provide evidence for its containment (Table 12). At the injection wells, DTS data will help reveal relatively high injectivity units within the reservoir zone taking fluid. At the in-zone observation wells, the DTS data will allow for detection of CO₂ breakthrough. PNC logging at injection wells will also reveal units with higher injectivity as well as provide quantitative measurements of CO₂ saturation within those units. Statistical approaches, e.g., normality testing, etc., will be used to identify CO₂ breakthrough at monitoring locations. PNC logging will occur in the injection wells as per the scheduled specified in this section. PNC logging will also be run in any in-zone observation well if there is a suspected CO₂ breakthrough, or any above-zone lowermost USDW observation wells with detected containment loss. DAS fiber optics will provide Tri-State CCS, LLC the ability to image the CO₂ plume in 3D within the reservoir as well as image the CO₂ plume should it migrate out-of-zone. Exact well locations with DAS deployment will be finalized based on final site characterization and land access agreements. Data from these technologies may be used to update reservoir models for more accurate CO₂ plume migration predictions.

The remainder of this page intentionally left blank.

Table 12: Indirect CO₂ plume injection phase monitoring activities.

Target Formation	Monitoring Activity	Monitoring Location(s)	Frequency
Lockport Dolomite and Medina Groups (Injection Interval)	DTS	TR2-1, TR2-2, TR2-3, TR2-4 TR2-IOB-1, TR2-IOB-2, TR2-IOB-3, TR2-IOB-4	Continuous
	PNC Logging	TR2-1, TR2-2, TR2-3, TR2-4	Three years after injection begins, and every five years thereafter during the injection period.
	PNC Logging	TR2-IOB-1, TR2-IOB-2, TR2-IOB-3, TR2-IOB-4; TR2-AOB-1, TR2-AOB-2; TR2-UOB-1, TR2-UOB-2, TR2-UOB-3, TR2-UOB-4	PNC logging will only occur in wells with detected CO ₂ breakthrough and suspected containment loss.
	Repeat 3D DAS VSP/CSP	TBD ¹	TBD

¹ While DAS is planned to be included in some of the wells, the exact wells and the exact frequency will depend on the evolution of the plume and independent observations from other monitoring methods over time.

9.3. Pressure-Front Monitoring Location and Frequency

Tri-State CCS, LLC will use permanent electronic DH pressure gauges placed above the packer and ported through to monitor each well’s respective monitoring zone (see Table 1) pressures continuously. This includes injection zones in both the Lockport Dolomite Group and the Medina Group. Wellhead pressure gauges will be installed as a backup pressure measurement should the DH gauges fail. DH and surface pressure gauges will be installed in all injection wells and in-zone, above-zone, and lowermost USDW observation wells (Table 13).

9.4. Pressure-Front Monitoring Details

Tri-State CCS, LLC will directly monitor the presence of the elevated pressure front by deploying electronic DH pressure gauges within every completion zone of each injection well, as well as within the in-zone, above-zone, and lowermost USDW observation wells. Injection and in-zone observation wells will monitor the evolution of the CO₂ plume in the Lockport Dolomite Group and Medina Group reservoirs during injection. Above-zone and lowermost USDW observation wells will monitor for pressures and temperature changes indicating potential containment loss in the Oriskany Formation and Mauch Chunk Group (lowermost USDW), respectively. All DH gauges and instruments will be comprised of a corrosion resistant chrome alloy and will continuously record formation pressure and temperature from fixed-point locations at a set sampling interval.

Table 13: Direct pressure-front injection phase monitoring activities.

Target Formation	Monitoring Activity	Monitoring Location(s)	Spatial Coverage	Frequency
Mauch Chunk Group (Lowermost USDW)	P Gauges	TR2-UOB-1, TR2-UOB-2, TR2-UOB-3, TR2-UOB-4	Above Packer - Ported to Mauch Chunk Group (Aquifer)	Continuous
Oriskany Formation (First permeable unit over confining zone)		TR2-AOB-1, TR2-AOB-2	Above Packer - Ported to Oriskany Formation	Continuous
Lockport Dolomite and Medina Groups (Injection Interval)		TR2-1, TR2-2, TR2-3, TR2-4 TR2-IOB-1, TR2-IOB-2, TR2-IOB-3, TR2-IOB-4	Above the Packer – Ported to Upper Lockport Dolomite and upper Medina Groups respectively	Continuous

Quality assurance procedures for these methods are presented in Section 2 of the QASP.

10. References

American Public Health Association (APHA), SM 2540 C (1997). “Standard Methods for the Examination of Water and Wastewater”, APHA-AWWA-WPCF Standard Methods 24th Edition.

API Specification 5CRA, (2023) “Corrosion-resistant Alloy Seamless Products for Use as Casing, Tubing, Coupling Stock, and Accessory Material”, American Petroleum Institute, <https://www.api.org/>

API Specification 5CT, (2019) “Specification for Casing and Tubing”, American Petroleum Institute, <https://www.api.org/>

ASTM Standard A53/A53M, (2022) “Standard Specification for Pipe, Steel, Black and Hot-Dipped, Zinc-Coated, Welded and Seamless”, ASTM International, DOI: 10.1520/A0053_A0053M-20, www.astm.org.

EPA 1971, (1982). “Method 150.1: pH in Water by Electromagnetic Method”, Cincinnati, OH.

EPA, (1993). “Method 300.0: “Methods for the Determination of Inorganic Substances in Environmental Samples.” Revision 2.1. Washington, DC.

EPA, (1994a). “Determination of Trace Elements in Waters and Wastes by Inductively Coupled Plasma – Mass Spectrometry.” Revision 5.4. Environmental Monitoring Systems Laboratory Office of Research and Development U.S. Environmental Protection Agency, Cincinnati, Ohio.

EPA, (1994b). “Determination of Trace Elements in Waters and Wastes by Inductively Coupled Plasma – Atomic Emission Spectrometry.” Revision 4.4. Environmental Monitoring Systems

Revision: 1
October 2025

Laboratory Office of Research and Development U.S. Environmental Protection Agency,
Cincinnati, Ohio.

American Public Health Association (APHA), SM2510 (1997). “Standard Methods for the Examination of Water and Wastewater”, APHA-AWWA-WPCF, Standard Methods 24th Edition.

American Public Health Association (APHA), SM 2320 B, (1997). Standard Methods for the Examination of Water and Wastewater, APHA-AWWA-WPCF, Standard Methods 24th Edition..

EPA, (1998). EPA Region 5 Guidance for Deep Injection Wells, Guidance 6: Planning, Executing, and Reporting Pressure Transient Tests.

EPA, (2008). EPA Region 5 Guidance for Deep Injection Wells, Guidance 5: Determination of the Mechanical Integrity of Injection Wells.

EPA, (2013). Geologic Sequestration of Carbon Dioxide, Underground Injection Control (UIC) Program Class IV Well Testing and Monitoring Guidance.

American Society of Mechanical Engineers (ASME), (2013). B40.100, Pressure Gauges and Gauge Attachments, American Society of Mechanical Engineers.

EPA, (2014a). “Method 6020B (SW-846): Inductively Coupled Plasma-Mass Spectrometry.” Revision 2. Washington, DC.

EPA, (2014b). “Method 6010D (SW-846): Inductively Coupled Plasma-Optical Emission Spectrometry.” Revision 4. Washington, DC.

ASTM Standard D513-16. 1988, (2016). “Standard Test Methods for Total and Dissolved Carbon Dioxide in Water,” ASTM International, West Conshohocken, PA. DOI: 10.1520/D0513-16, www.astm.org.

The National Association of Corrosion Engineers (NACE) Standard RP0775, (2018). Preparation, Installation, Analysis, And Interpretation of Corrosion Coupons: In Oilfield Operations, Houston, TX. ISBN 1-57590-086-6.